



Antique Style Pepper Grinder Fitting Guide

Please read this guide fully before starting.

As is often the case there is more than one way to complete these antique style pepper grinder kits. The method described below is to make a main shaft with separate bottom section to catch grinds that may fall from the grinder after use. We will also explain how to inset the mechanism into a blank – some makers may prefer to simply screw the kit on top of a blank – this is much easier and quicker but is not as secure or as aesthetically pleasing to the eye.

In this guide we will be using dovetail jaws on a chuck, this will mean a small amount of wasted blank – it is possible to pre-drill the centre shaft and mount on a jam chuck if preferred but you will need to complete the base/stand separately

The tools required for this project method are as follows:

25mm Forstner or auger bit
45mm forstner bit (optional)
8mm HSS/ Brad point drill bit (brad point bit is far more accurate for a good fit)
2.5mm HSS drill bit
Jacobs chuck (for drilling on the lathe)
Live centre
4-Jaw chuck with dovetail jaws.
Blank of 60mm square and 150mm long

Part 1 – to create the inset for the grinder base

- 1] If you are starting with a square blank mount between centres and turn round. Turn a tenon that will fit into your dovetail jaws.
- 2] Mount the roughly round blank into the dovetail jaws of the chuck – keep the blank in the chuck from this point. If you need to remove it remove the chuck as well.
- 3] With great care trim the blank to ensure the open end is flat and level
- 4] You can then remove the chuck and blank and mark the end of the blank and drill as shown in the diagram below:

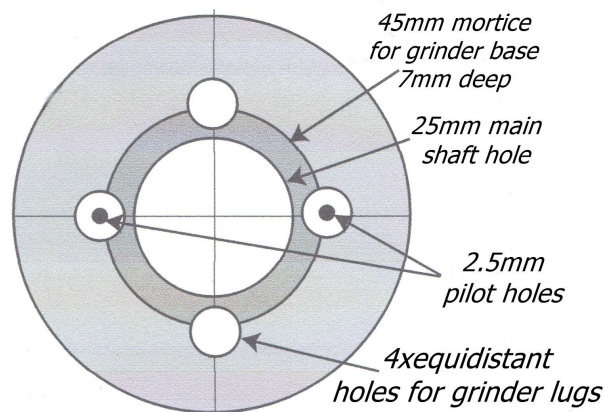

5] Once you have accurately marked the 4 points, above drill the 4 holes for the grinder lugs using an 8mm drill, drill down 7mm (please allow for the drill tip which may not be 8mm at it's point). Then drill 2 x 2.5mm pilot holes for the screws opposite each other (this can be done at the very end if you prefer)

6] Once the holes have been accurately drilled return the chuck and blank to the lathe

7] Using a 45mm forstner bit or turn by hand the 45mm mortice for the base of the grinder. You can use the kit itself to guage the fit if required, it should be 7mm deep

8] Once you are happy with the fit remove the kit, then drill using the 25mm forstner or auger bit to your desired length. The length drilled will be the height of the grinder body. For our 150mm blank we drilled 100mm

9] Using a narrow parting tool make a mark at 100mm, this is where the body will be parted off when finished.

10] Bring up a live tailstock for support and you can now shape and finish the main body as required. The base of the body should be turned to 50mm – it will need to fit inside the separate base

11] Once finished part off the body and finish the base and inside by hand with a suitable food grade finish.

12] If you have not drilled the screw pilot holes already, drill the 2 holes for the screws, place the kit in the mounting mortice and carefully secure with the 2 screws. The screws sit just under the rim of the grinder hopper and have to be accessed at a slight angle. Use a PH1 (Philips head size 1) screwdriver and gently screw in the screws taking care not to strip the heads out.

The grinder fitting and main body are now finished

PART 2 – The Base / stand

Once the main body has been removed you will be left with approx 40mm length of blank left in the chuck.

1] Turn the inside of this part fractionally larger than the base of the main body and use the main body as a guide to get a good fit

2] Mark with a narrow parting tool the bottom of the base / stand to your desired height

3] You can now shape and finish the base as required and once finished part the piece off and finish the bottom by hand.

By using this method it enables continuity in the woodgrain of the finished product.

And finally.....

The grinder adjusts with b releasing the top knob and then adjusting the flat nut underneath clockwise for finer grind (raises the burr), anti-clockwise for coarser grind (lowers the burr).

Once the grind size is achieved re-tighten the top knob which will retain the grind size.

If the grinders bind do NOT force the handle, turn the adjuster anticlockwise until the mechanism moves freely.

The grinder is ready for use and is suitable for pepper and many other herbs and spices – it is NOT suitable for grinding salt.

